

INSIGHT II

scanners

INTEGRATED FLAME SCANNER WITH TWO INTERNAL FLAME RELAYS

Type 95DSS3



The FIREYE InSight II Type 95DSS3 flame scanners are micro-processor based flame scanners utilizing both solid state infrared (IR) and ultraviolet (UV) sensors.

The FIREYE InSight II flame scanners incorporate two internal flame relays with adjustable ON/OFF thresholds and two 4-20 mA analog outputs, thereby eliminating the need for a remote flame amplifier.

The FIREYE InSight II scanners are powered by 24 Vdc and have electronic self checking. Model 95DSS3-1 has one 8-pin and one 12-pin electrical cable quick disconnect. Models 95DSS3-1CEX and -1WICEX have internal terminal blocks for cable connection. The scanners have either an attached Keypad & VFD display, or an infrared transmitter for a remote handheld keypad / display.

INSIGHT II SCANNER FEATURES

Features

Models

	95DSS3-1	95DSS3-1CEX	95DSS3-1WICEX
Infrared & Ultraviolet Sensors	✓	✓	✓
Flame Relays (2)	✓	✓	✓
Fault Relay	✓	✓	✓
4-20 mA Outputs (2)	✓	✓	✓
Modulation Frequency Selections	21	21	21
Memory Files	4	4	4
Communications	✓	✓	✓
Auto Config	✓	✓	✓
NEMA 4X, IP66 Housing	✓	✓	✓
Keypad & VFD Display	ordered separately	✓	
IR Transmitter for remote handheld display	ordered separately		✓
Area Classification:			
Class I DIV 2, Group A,B,C,D,F,G	✓		
Ex nA nC IIC T4	✓		
Ex d IIC T6		✓	✓

INSIGHT II SCANNER DIMENSIONS

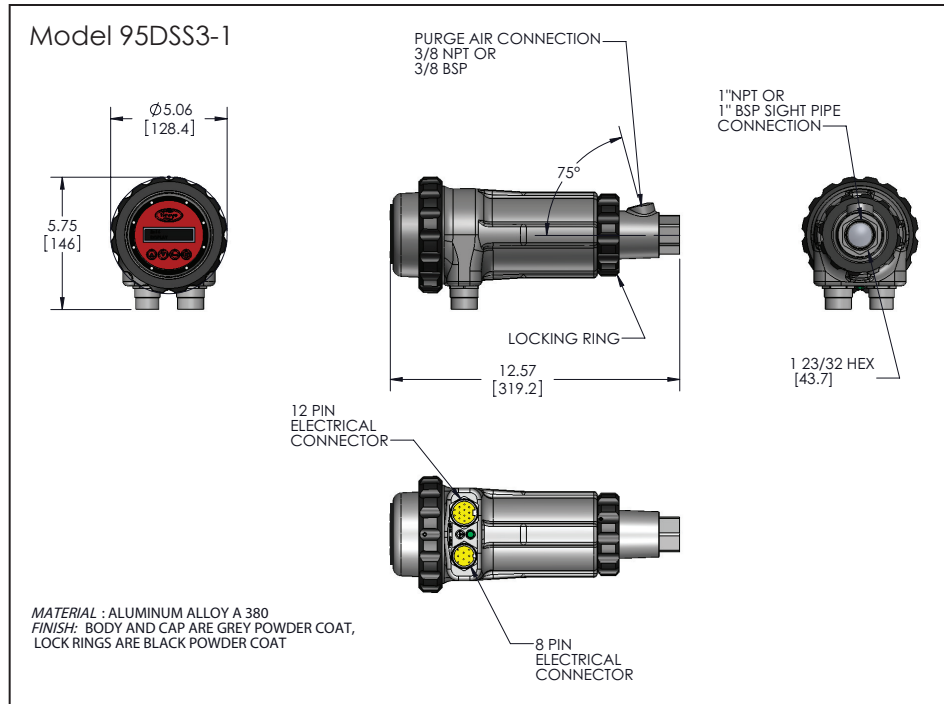

INSIGHT II SCANNER SPECIFICATIONS

MECHANICAL:

Housing Material:	Cast aluminum with gray polyester powder coat finish
Housing Weight:	5.9 lbs (2.69kg), 7.1 lbs (3.22kg) "CEX" models, flange additional
Environmental:	NEMA 4X, IP66
Area Classification:	95DSS3-1: Class I Div 2, Groups A, B, C, D, Class II Div 2, Groups F & G 95DSS3-1CEX, -1WICEX: Ex d IIC T6
Mounting:	Requires one of two threaded mounting flanges, ordered separately (see below)
Mounting Flanges:	Contains an integral heat-insulating female thread insert (heat insulating nipple not required).
Flange Threads:	P/N 60-2919-1 1" NPT female pipe mount with 3/8" NPT female cooling air connection. P/N 60-2919-2 1" BSP female pipe mount with 3/8" BSP female cooling air connection.
Mounting Flange Weight:	0.62 lbs (0.28kg)
Cooling / Purge Air Requirements:	Source: Clean, dry cool Volume: 4 SCFM (113 l/min) at 3/8" threaded mounting flange, or 1 inch "Y" fitting, mounted on scanner sight pipe. Temperature near the upper limit of the scanner operating range and/or use with dirty/dusty fuels may require up to 15 SCFM (425 l/min).
Temperature Rating:	-40° to +150°F (-40°C to +65°C)
Humidity:	0% to 95% relative humidity, non-condensing

ELECTRICAL:

Input Power:	24 Vdc, +10%, -15% supply current .35 A, 8.5 VA
Electrical Connection:	8-pin and 12-pin screw type quick disconnect (non-CEX). "CEX" models have internal terminal blocks
Relay Output:	FLAME RELAY 1, SPDT (1 N.O., 1 N.C.) FLAME RELAY 2, SPDT (1 N.O., 1 N.C.) FAULT RELAY, SPST (1 N.O.)
Contact Rating:	Minimum: 10mA @ 5 Vdc Maximum: 100 mA @ 30 Vdc, 100 mA @ 50 Vac
Analog Output:	Two, 4-20 mA dc current, referenced to 24 Vdc common, maximum connected load: 750 ohms
Operator Interface:	P/N 95DISP-1 Alpha -Numeric Display with five push button keys. P/N 95WIDISP-2 Infrared Transmitter, used in conjunction with P/N 95WIHH-2 hand-held communications tool.
Cable Specification:	P/N 59-546 (8-conductor), P/N 59-547 (12-conductor): Multi-core, 8 and 12 conductor (color coded), 18- AWG, with foil wrap and overall braided shield and drain wire. PLTC-ER rating. Maximum cable length 1000 feet (305 meters) Cable Jacket: PVC / black (flame-retardant, low smoke, zero halogen) Temperature Rating: -40 F to +221 F (-40 C to +105 C) P/N 59-546 Nominal O.D. 0.44" (11.2 mm), maximum O.D. 0.48" (12.2mm) P/N 59-547 Nominal O.D. 0.52" (13.2 mm), maximum O.D. 0.56" (14.2mm) Maximum cable length 1000 feet (305 meters)



Thinking Beyond the Traditional...

3 Manchester Road
Derry, NH 03038 USA
tel: 603-432-4100 • fax: 603-432-1570
www.fireeye.com